



Installation, Operating,
Maintenance and Safety Instructions
JABSCO 53040 & 53041-Series
1" 40 SIZE "UTILITY" Pump



TO OBTAIN THE BEST PERFORMANCE FROM YOUR JABSCO
PUMP PLEASE READ THESE INSTRUCTIONS CAREFULLY

*Failure to observe the recommended procedures may result in
early and severe damage to your JABSCO pump and may also
invalidate the supplier's guarantee.*

DOC591/12

Installing Your "UTILITY" Pump

1. Locate the pump as close to the liquid source as practicable. The pump will self-prime quickly from dry to 2 metres or more when new. The pump should be mounted horizontally, with the discharge port vertically upwards. The pump itself is capable of operating in any position, but for the full benefit of its built-in dry-running protection it should be located on a more or less horizontal surface.
2. **Rigid pipework** must be adequately supported to avoid stress and possible distortion of the pump body, with consequent leakage.
3. **Flexible pipework** must be airtight to ensure reliable self priming. Inlet hose must be reinforced to prevent deformation or collapse under suction conditions. Use minimum 1" bore hose.
4. **Operation** - see pump data sheet for maximum recommended discharge pressures. Do not run the pump above this recommended maximum. Do not operate the pump against a closed discharge. If necessary, flow rate may be controlled by running a valved branch from the discharge line back to the liquid source.

AC MOTOR PUMP UNIT

ALL ELECTRICAL WIRING should be connected and installed by a competent electrician. A qualified person must ensure that the installation conforms to the Electrical and Mechanical requirements of Local and National Regulations. All equipment operating within a flameproof area must comply with the relevant standards applying to that area. Before using the pump, ensure that your electrical supply corresponds with the voltage marked on the machine.



WARNING - THIS APPLIANCE MUST BE EARTHED.

IMPORTANT - 110V UTILITY PUMP ELECTRIC SUPPLY

The 110 volt motor starting current is approximately 25 amps. To avoid excessive voltage drop on start up it is essential that a transformer or generator of 3kVA minimum be used.

The supply voltage during start up should not fall below 104 volts **measured at the motor**. Use cable of adequate size to avoid excessive voltage drop. A voltage lower than this may result in poor performance and/or burning out.

If in doubt consult a qualified electrician

Use of a proper electrical starter is strongly advised.

A starter will

- protect the motor (a fuse will protect only the wiring)
- prevent accidental restarts after power failure
- withstand the heavy starting current of the motor
- provide a safe, waterproof switch enclosure.



**Motors are not flameproof and can spark;
Explosion and death can occur.**



WHERE CAPACITORS are employed in motor circuits, a charge is retained after the supply has been isolated. This must be discharged before touching motor terminals to avoid the risk of an electrical shock.

DIRECTION OF ROTATION - The pump must rotate clockwise viewed from in front of its brass end cover. Single phase a.c. motors, correctly wired, will rotate in the correct direction. With 3-phase units, start the pump briefly to check direction of rotation (remove motor fan cover or pump end cover to check). If rotation needs to be reversed, exchange any 2 power lead connections in the terminal box.

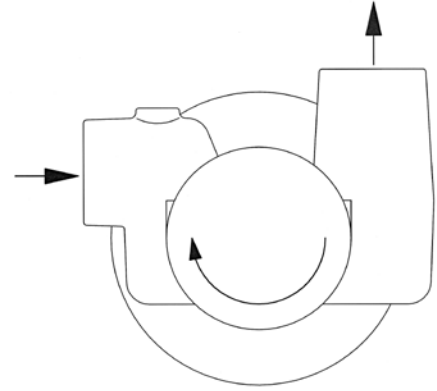

TEMPERATURE: Operating range	-	Neoprene Impellers	4°- 80°c
		Nitrile Impellers	10°- 90°c

LABELS should be attached to all services over 60°c, indicating "Hot Areas".

PRIMING

The JABSCO Utility pump can safely self-prime from dry, and does not need to be filled with liquid before starting. However, the pump will prime more rapidly, will generate a higher suction lift, and will be better protected against dry running on first use, if filled with liquid first.

CHECK on first start-up that the pump has primed itself within a few seconds. If a steady flow is not established within 20 - 30 seconds, **STOP THE PUMP** and investigate the cause. Check the inlet line carefully for air leaks. If problems persist, check that the end cover is tight, the O-ring seal is clean, the cam screw and cam itself are properly sealed in the body, and that the shaft seal is undamaged and correctly fitted.

DRY-RUNNING - Properly installed and filled with liquid before use, the JABSCO Utility pump is protected against dry-running damage for up to 30 minutes. See pump data sheet for further details.

SAFETY ADVICE

Ensure that all moving parts are adequately guarded to prevent accidental contact. Leakage from the mechanical seal could cause a hazard, or damage to the pump or motor. If the seal leaks, stop the pump and change the seal. Prolonged running with a leaking seal will invalidate the supplier's warranty. If the liquids being pumped are toxic or corrosive the use of a drip tray is recommended.

DO NOT USE this pump for Petrol, Toluene, Benzene or light fraction petroleum products such as solvents, thinners or liquids with a flash point below 37°c.

FREEZING TEMPERATURES - do not permit liquid to freeze in the pump body. Drain the pump by loosening the end cover.

SERVICE INSTRUCTIONS

DISASSEMBLY - *Inspect all parts for wear and damage and replace if necessary.*

1. Remove end cover screws, end cover and "O"-ring.
2. Remove impeller using swan neck pliers or JABSCO impeller removal tool (ask your supplier for details). Do not use a screwdriver to lever the impeller out, as this may damage the pump body.
3. Remove cam screw and cam, clean off any old jointing compound.
4. Remove wear plate
5. Remove body to motor screws, pull body away from motor flange.
6. Remove cup rubber and ceramic from the pump body and pull the mechanical seal from the motor shaft. Do not remove spacer unless the motor is to be replaced.

ASSEMBLY

1. Assemble spacer on to motor shaft so that the front face is 9.15mm from the face of the motor mounting plate. If the spacer has not been removed check that the spacing is correct.
2. Push the mechanical seal on to the motor shaft up to the spacer. Fit cup rubber and ceramic into seal bore in body.
3. Fit wear plate in impeller bore, radius side to the bottom of the bore.
4. Coat cam screw threads and outer surface of cam with a non-setting jointing compound and install in pump.
5. Slide body over motor shaft, take care not to damage the seal. Secure with screws.
6. Lubricate impeller with waterproof grease and install.
7. **NOTE:** make sure that impeller vanes are deflected for clockwise rotation when looking at the front end of the pump.
8. Fit "O" ring and end cover and secure with screws.

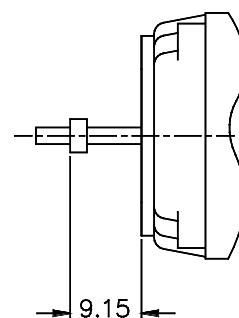

IT IS A REQUIREMENT OF COSHH (1988) REGULATIONS THAT IN THE HANDLING OF HAZARDOUS SUBSTANCES THE PRODUCER'S INSTRUCTIONS MUST BE OBSERVED AT ALL TIMES.

To conform to Health and Safety and COSHH Regulations, the supplier requires that any pump or part of a pump that is returned for repair or examination, or for any reason whatsoever, will be suitably packed and accompanied by a letter stating what the pump/part has been pumping.

If the liquid or product is hazardous or in any way dangerous, this must be stated, and the chemical make-up of it must be stated in detail.

Unless this procedure is observed, delivery of the unit will not be accepted by the supplier. The only exception to this rule is if the pump returned is new and unused.

JABSCO UTILITY PUMP 53040 and 53041 series PARTS LIST

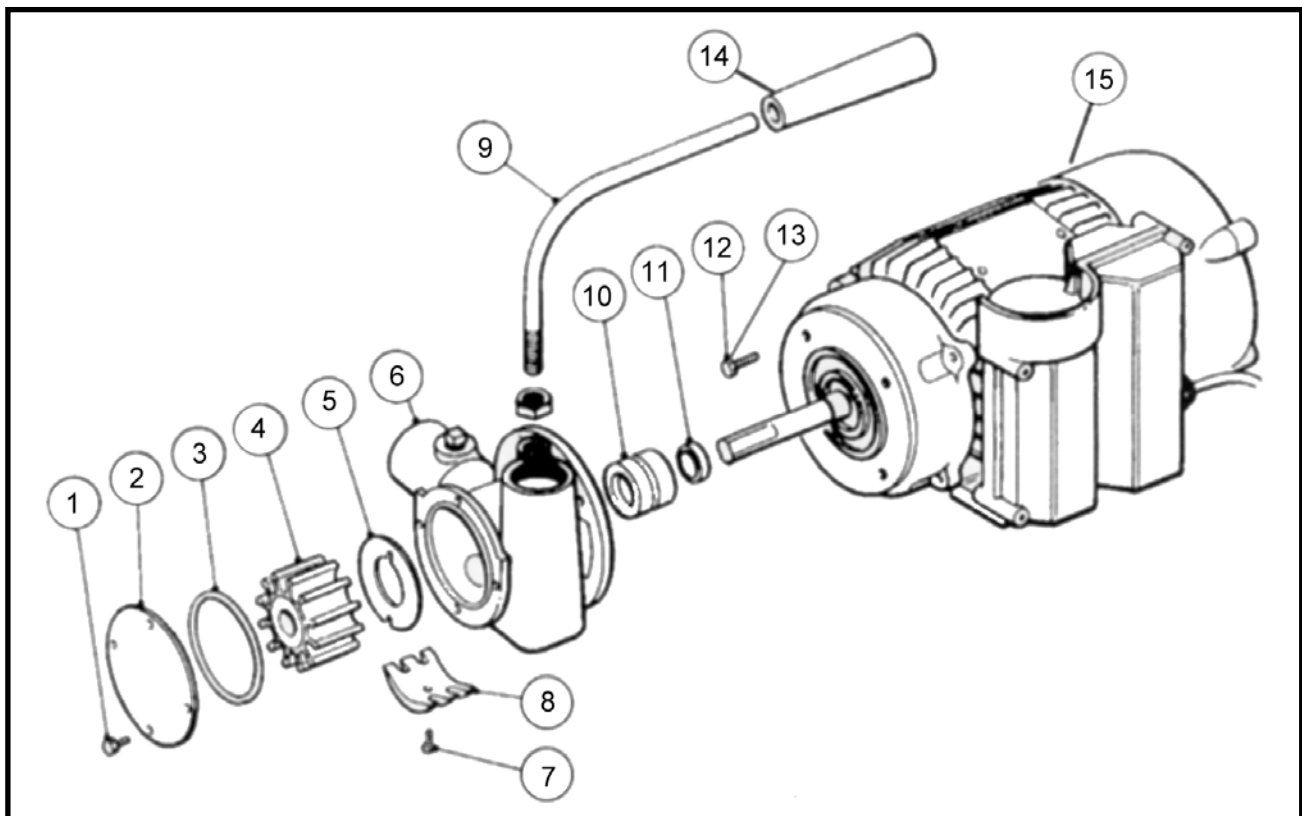

KEY	DESCRIPTION	QTY	PART NUMBER
1	Endcover Screws	4	X3001-147F*
2	End Cover	1	23825-0000
3	'O'ring	1	X4020-259A*
4	Impeller All Models 53040-2003, 53040-2053, 53041-2003-XXX and 53041-2053-XXX All Models 53040-2001, 53040-2051, 53041-2001-XXX and 53041-2051-XXX	1 1	14281-0003* 14281-0001
5	Wearplate	1	9486
6	Body	1	23824-2000
7	Cam Screw All Models 53040-2003, 53040-2001, 53041-2003-XXX and 53041-2001-XXX All Models 53040-2001, 53040-2051, 53040-2001-XXX and 53040-2051-XXX	1 1	SP1003-01 SP1003-09
8	Cam All Models 53040-2003, 53040-2001, 53041-2003-XXX and 53041-2001-XXX All Models 53040-2053, 53040-2051, 53041-2051-XXX and 53041-2053-XXX	1 1	23826-0000 23827-0000
9	Handle	1	53083-0000
10	Seal Assembly	1	22626-6000*
11	Spacer Assembly	1	23828-1000
12	Body Screws	4	X3001-178F
13	Washers	4	X3081-091F
14	Handle Grip	1	X5255-005
15	Motor Models 53040-2003, 53040-2053, 53040-2001 and 53040-2051 Models 53040-2103, 53040-2153, 53040-2101 and 53040-2151 All Models 53041-XXXX-110 All Models 53041-XXXX-230 All Models 53041-XXXX-400 All Models 53041-XXXX-24D	1 1 1 1 1 1	SP8012-0212 SP8012-0239 MJB40U-110 MJB40U-230 MJB40U-400 Z/P108